

## Modular dv/dt Pulse Generator Testbench for Insulation Endurance Assessment

**Benjamin Sahan, Christian Staubach, Kevin Kaczmarek, Stefan Reddig, Konrad Domes, Philipp Berkemeier, Felix Schönlebe**

Suggested citation:

Sahan, Benjamin, Christian Staubach, Kevin Kaczmarek, Stefan Reddig, Konrad Domes, Philipp Berkemeier, and Felix Schönlebe. 2024. "Modular dv/dt Pulse Generator Testbench for Insulation Endurance Assessment." *Bodo's Power Systems*. <https://doi.org/10.25968/opus-3119>.

### Abstract

The collaborative effort between SAXOGY® and Hannover University of Applied Sciences has resulted in the development of an advanced modular dv/dt pulse generator. This innovative testbench represents a significant leap forward in accelerated insulation endurance testing. It offers a valuable tool for validating existing and developing new insulation systems, thereby contributing to the enhancement of future power electronic systems.

# Bodo's Power Systems®

## Modular dv/dt Pulse Generator Testbench for Insulation Endurance Assessment – Part 1

Power electronics technology is advancing continuously. However, this also results in new requirements. The insulation systems of rotating machines, transformers, cables, or bearings experience significantly higher stress due to the steep  $du/dt$  voltage pulses generated by the inverter. In particular, the rapid progress in fast-switching devices presents new challenges that must be addressed by insulation material manufacturers and system integrators.

By Prof. Dr. Benjamin Sahan, Prof. Dr.-Ing. Christian Staubach, B. Eng. Kevin Kaczmarek, B. Eng. Stefan Reddig (Hannover University of Applied Sciences), and Dipl. Ing. Konrad Domes, M.Sc. Philipp Berkemeier, M.Sc. Felix Schönlebe (SAXOGY POWER ELECTRONICS GmbH)

This trend is further amplified by the increasing system voltage in many applications, as observed in electric vehicles (400 → 800V) and PV systems (1000 → 1500 V). The application of steep inverter  $dv/dt$  slopes leads to increased stress compared to the traditional 50 Hz sinusoidal voltage for some of the following reasons:

- Reduced partial discharge inception voltage (PDIV) and increased partial discharge activity
- Inhomogeneous voltage distribution within the windings [1]
- Polarization effects and dielectric heating due to displacement currents

Figure 1a. illustrates a twisted wire test specimen undergoing stress during inverter operation. Strong corona discharge activity is clearly visible to the naked eye.

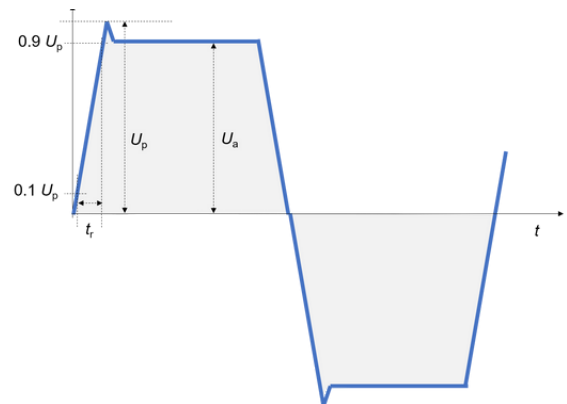
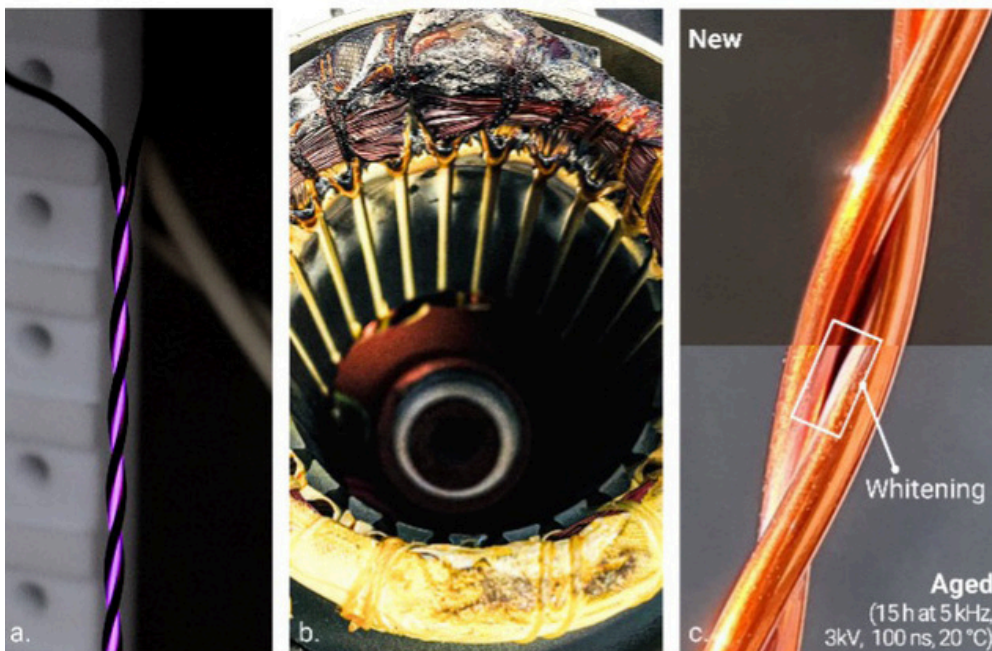

Figure 2: Specification of the voltage waveform over one period



In Figure 1c, a conventional enamel wire insulation, also configured as a twisted pair, underwent testing with pulsed voltages, revealing distinct indications of partial discharge erosion. Lastly, Figure 1b shows an example of a destroyed motor as a result of failed insulation. Under these challenging operating conditions, precise knowledge of the aging process and the ability to estimate the remaining lifespan of the insulation system are crucial.

SAXOGY® and Hannover University of Applied Sciences have taken on the task of developing a test bench that realistically simulates the stresses of inverter operation and can be used for accelerated insulation endurance assessment. The corresponding project "ISODyn" was supported by the German ZIM research funding.

Figure 1a. test specimens with strong corona discharge; Figure 1b. motor example; Figure 1c. twisted pair wire after endurance testing (tested at Hannover lab)

### Which requirements are used for testing?

Currently, there is no unified international standard for endurance testing under high-frequency voltage impulses for winding wires. Therefore, we refer to the existing chinese standard GB/T 4074.21-2018 and incorporate feedback from manufacturers to derive the following requirements according to figure 2 that the  $dv/dt$  pulse generator must meet.

- Voltage waveform: Bipolar square wave
- Peak voltage: 1,5 kV (should be modular extendable)
- Rise time  $t_r > 25$  ns (10-90%) – adjustable
- Max. voltage slope  $dv/dt$ : 60 kV/ $\mu$ s
- Pulse frequency: 20 kHz
- Test temperature  $> 180$  °C
- Voltage overshoot  $(1-U_p/U_a) < 2\%$
- Grounding of the device under test

The breakdown of motor windings due to insulation failure occurs when the insulation degrades over time under the influence of steep  $dv/dt$  voltage pulses. This degradation can lead to arcing, ultimately reducing the insulation resistance and resulting in a breakdown. Reliable detection of this breakdown is necessary to prevent damage to the test bench and accurately define the resulting lifetime.

### Factors influencing insulation lifetime

Various measurements are carried out in endurance tests. The ensuing results were subjected to statistical analysis. The test samples consists of twisted pair copper wires that met the specifications of the IEC 60851 standard.

**Probability Plot**  
Weibull - 95%-CI

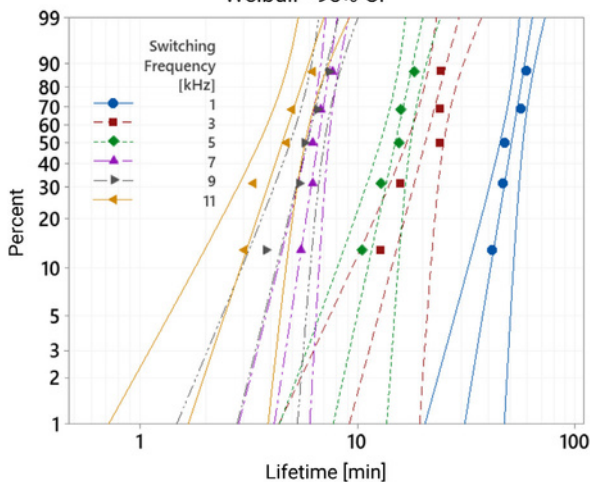

Figure 3: Probability plot of the electric lifetime depending on the switching frequency

First, the influence of the pulse frequency  $f_p$  on the resulting electric lifetime of conventional copper wire enamels without additives is investigated (see Figure 3). The samples failed after about 4 min (for 11 kHz) to about 55 min (for 1 kHz) in average. It can be summarized as follows:

- the electric lifetime decreases almost lineary with increasing frequency  $f_p$

Additionally, the effects of slew rate, temperature, and insulation material on the resulting lifetime has been investigated, examining different combinations of rise time ( $t_r$ ) and oven temperatures [2].

- variations in rise time have a noticeable impact on lifetime (see Figure 4)
- increasing the temperature reduces the electric lifespan (see Figure 4)

**Boxplot of Standardized Average Lifetime**

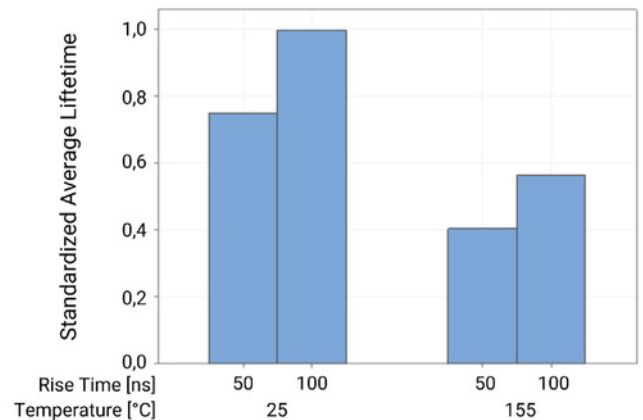

Figure 4: Impact of rise time and temperature on lifetime for conventional copper wire enamels

Furthermore, the choice of insulation material and its structural composition were found to significantly influence the overall life-time [2].

### Unique modular $dv/dt$ pulse generator test bench for lifetime testing

SAXOGY POWER ELECTRONICS and Hannover University of Applied Sciences have jointly developed a modular high-voltage pulse generator, as shown in figure 5.

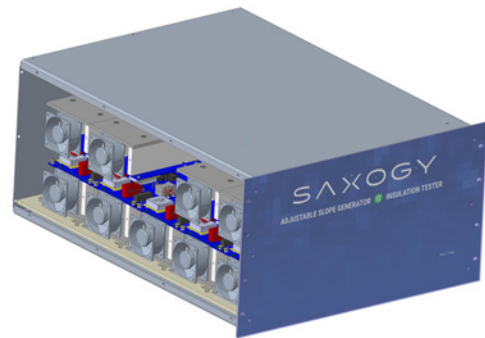

Figure 5: SAXOGY's sketch of the power unit of the  $dv/dt$  pulse generator

This generator consists of state-of-the-art SiC MOSFET technology. It is designed to be adaptable allowing for expansion to fulfill the specific test requirements for lifetime testing and upcoming standards in terms of insulation testing.

The concept is scalable and can be expanded to meet specific application needs. The bipolar voltage waveform is adjustable across a broad voltage range, from 0,4 kVpp to 12 kVpp, depending on the configuration and the generator can achieve voltage slopes up to 200 kV/ $\mu$ s.

### Adjustable load settings

A precise gate driver circuit has been developed to ensure that the overshoot of the SiC inverter remains below 2%.

Furthermore, an almost linear voltage gradient was achieved during the switching time, ensuring a consistent stress in every rising and falling edge. To adjust the stress level, there are 16 steps to fine-tune the voltage slope based on the requirements of the individual insulation testing standard. To vary the test time for accelerated endurance tests, the generators square wave frequency can be set between 2 kHz and 20 kHz.

In addition to the electrical key figures for insulation testing, the development focused on two essential requirements for an insulation endurance test bench:

1. the generator must never exceed its own insulation limits and cause stress to itself
2. Most insulation tests end with an insulation breakdown, which from the generator's point of view represents a low impedance short-circuit. This short-circuit current must be detected and handled within microseconds. This process is repeated beyond the device's lifetime.

Further details regarding the development of the pulse generator and its various configurations will be elaborated upon in part 2 of this article.

**Research and development in accelerated insulation endurance testing**

The collaborative effort between SAXOGY and Hannover University of Applied Sciences has resulted in the development of an advanced modular  $dv/dt$  pulse generator. This innovative testbench represents a significant leap forward in accelerated insulation endurance testing. It offers a valuable tool for validating existing and developing new insulation systems, thereby contributing to the enhancement of future power electronic systems.

Outlook: Given the importance of the topic, a subsequent article will be published next month. Part 2 will dive into the design and challenges of the novel  $dv/dt$  generator test bench.



[www.saxogy.de](http://www.saxogy.de)

Bodo's Power Systems® · bodospower.com

**References**

- [1] WEG technical guide "Induction motors fed by PWM frequency inverters" <https://static.weg.net/medias/downloadcenter/hcb/h20/WEG-induction-motors-fed-by-pwm-frequency-inverters-50029350-brochure-english-web.pdf>
- [2] C. Staubach et al. "Inverter voltage endurance testing of twisted pairs acc. IEC 60851 with a self-developed, adjustable generator" IEEE Electrical Insulation Conference (EIC), 2024 (accepted for publication)

**SAXOGY POWER ELECTRONICS GmbH and the Hannover University of Applied Sciences**

Since 2020, SAXOGY has been actively collaborating with Hannover University in the form of research and business projects. The project "ISODyn – dynamic, modular testing device for modern insulation systems in electric motors" described in the article was funded as part of the BMWi's Central Innovation Program for SMEs (ZIM).

**The result was:**

- functional prototype test generators
- a complete test bench for examining the influence of highly dynamic voltage pulses on insulated wires, including evaluation software
- new measurement data and insights into aging mechanisms of insulation
- market-ready testing device for testing insulation systems
- further developments to increase safety when dealing with high voltages (e.g. SAXOGY's safety measuring box)



Konrad Domes



Benjamin Sahan

**SAXOGY**  
POWER ELECTRONICS

# Testbenches for each evolution stage.

**SAXOGY POWER ELECTRONICS GmbH**  
[www.saxogy.de](http://www.saxogy.de)

Bodo's Power Systems® · bodospower.com

# Modular dv/dt Pulse Generator Testbench for Insulation Endurance Assessment – Part 2

*The development of power semiconductors, particularly WBG devices, has progressed significantly. This advancement has resulted in higher blocking voltages, reduced switching losses due to faster switching times, and the ability to create more compact systems by reducing passive components and optimizing space in power electronic systems.*

*By Dipl. Ing. Konrad Domes, M.Sc. Philipp Berkemeier, M.Sc. Felix Schönlebe  
(SAXOGY POWER ELECTRONICS GmbH)*

*Prof. Dr. Benjamin Sahan, Prof. Dr.-Ing. Christian Staubach, B. Eng. Kevin Kaczmarek,  
B. Eng. Stefan Reddig (Hannover University of Applied Sciences)*

## Failure of insulation systems due to power electronics

Despite these advantages, many developers and system engineers are not fully aware of the potential drawbacks of faster switching semiconductors. The development of fast power semiconductors bears new risks and challenges for established electrical systems, particularly the insulation system. It is important to consider these potential threats.

The first part of this article presented a current research topic on endurance tests of enamelled copper wires, to test for example the insulation system of motor windings. A few questions may have arisen:

- Have you ever wondered how much your insulation materials are stressed by up to 200 kV/us voltage slopes?
- Do you know how much displacement current will flow in your insulated hairpin wire under steep voltage pulses and how this affects the lifetime of the winding?
- Are you as a semiconductor manufacturer aware of the aging process of your packaging technology?

## SAXOGY's approach for a high voltage dv/dt pulse generator testbench

To develop the required test equipment, a circuit topology is needed that generates high voltage slopes and amplitudes while ensuring permanent non-destructive operation. SAXOGY® has developed an innovative circuit concept over the past two years that meets the new load requirements

for a scalable high-voltage insulation test system for various applications. Figure 1 presents the hardware components of the pulse generator and Figure 2 shows a prototype of a complete testbench.

Traditional solutions are reaching their limits due to fast switching components. To avoid overloading our system and risking its destruction, it has been designed as

a multi-level system and developed with a strict insulation approach. While not exceeding the standard usage level of the components, we attain voltage slopes that are often multiple times greater than usual.



Figure 1: SAXOGY's Adjustable Slope HV-Generator

Due to the high required dv/dt and excellent adjustability, it quickly became apparent that SiC-MOSFETs should be used.

However, as there was no single device that meets the requirements regarding breakdown voltage, it was necessary to connect multiple standard devices in series.

Direct series connection, is complex, which led to a cell-based cascaded H-bridge topology.

Simultaneously switching individual cells can significantly increase the output voltage slope, depending on the number of cells used. For example, if a single cell switches with a slope of 20 kV/μs, the slope can triple to 60 kV/μs

if three cells are involved in generating the output voltage.

Traditionally, the cascaded H-bridge requires individual transformers in each cell for the power supply. However, these transformers exhibit high coupling capacitances, resulting in increased displacement currents. This can pose a risk of damaging the insulation and ultimately lead to transformer failure over time. Hence, SAXOGY® has invented an innovative topology that operates with only a single power supply and at the same time can be extended for higher voltage levels. The inverter topology is extended with an additional charging path. Similar to the principle of a "bucket chain", energy is transferred from the power supply unit into the first cell and, in the next step, energy is passed on from the first to the second cell. This process continues until the top cell in the system has also been recharged and the charging sequence starts all over again. To ensure that the recharging of two cells



Figure 2: Example of an early prototype testbench

works, one cell operates as a «charging cell» and cannot provide any voltage at the output for the duration of charging. All cell voltages in the system can be maintained by matching the charging frequency to the application.

Figure 3 displays the topology of the SAXOGY® dv/dt pulse generator, using a three-stage system with a supply voltage of 750 volts. The switching configuration for positive output voltage and charging of cell two is shown. Cell one functions as a charging cell and does not output any voltage, but is connected in parallel to cell 2 via the switch T5. The current flow (red arrow) between the DC link capacitances is limited by a current rise-limiting inductance and a diode in the charging path, which also prevents oscillations in the resonant circuit. Alternatively, a current-limiting resistor can be used instead of the inductance, but this results in additional losses and reduces the recharging efficiency.

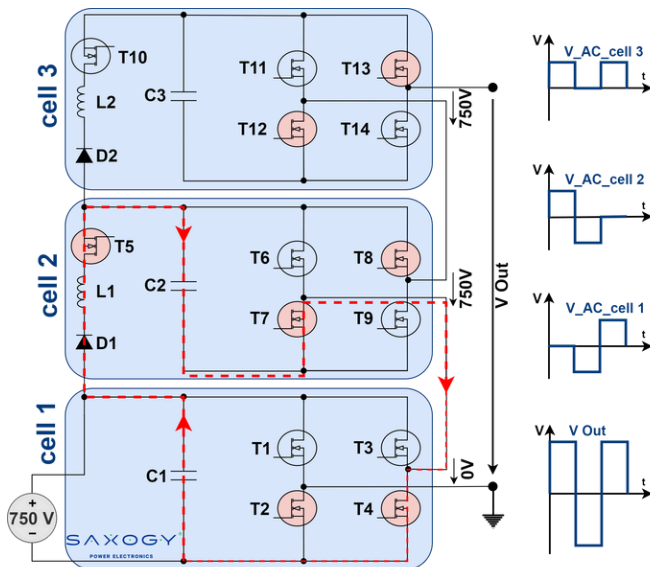

Figure 3: SAXOGY's advanced transformerless multi-level topology

**Setting the correct stress level for your insulation**

Thanks to the modularity of the topology, the output voltage can be adjusted as required by the application. To cover current and future insulation tests, the generator can provide bipolar voltages from 0,4 kVpp to 12 kVpp.

The rectangular voltage waveform can be set in a wide range from 2 kHz to 20 kHz to apply additional stress to the test specimen and shorten the test duration.

As demonstrated by the research findings in the first part of this article, doubling the rise times results in roughly halving the lifetime of an insulation system. To vary the rise time, we used a high level of expertise to dynamically adjust the voltage dv/dt slope in real-time using a self-developed gate driver. This ensures an almost linear voltage slope, resulting in a constant displacement current over the entire voltage rise.

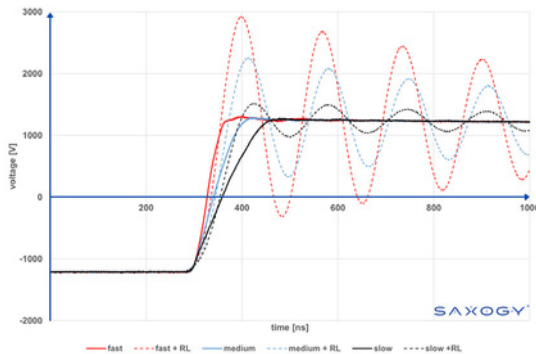

Figure 4: Adjustable rise times and optional overshoot via passive network

The gate driver is designed to enable a switching behavior that keeps the generator voltage overshoot below 2 %. Figure 4 demonstrates the adjustability of the voltage gradient at 1200 V and the almost linear voltage slope by displaying three out of sixteen voltage gradient settings. To expand the range of applications for the high voltage dv/dt generator, an additional overshoot can be generated by using external passive RL-networks (dashed lines). This enables testing of motor windings in worst-case scenarios.

The generator is addressed via Modbus TCP and is therefore very easy to operate.

**Tailored solutions for your needs**

The pulse generators are customized according to your specific requirements to create an optimal test bench. They are available in different versions, all housed in a 19" rack-mountable enclosure. The most suitable variant for you depends on your needs and the associated integration costs.

**OPTION: COMPLETE SYSTEM**  
This includes for example the integration of an oven for environmental simulation, maximum safety monitoring, measuring equipment and further desired features for your application.

**OPTION: MAXIMUM SAFETY**  
The Safety-variant contains beside the HV-isolator switch an integrated safety PLC. It enables maximum safety during the tests with performance level e.

**OPTION: HV-ISOLATOR SWITCH**  
This design option includes an additional high voltage switch to disconnect the generator output voltage.

**SAXOGY®-STANDARD**  
Includes the main electrical properties to generate adjustable stress like setting the voltage amplitude, square wave frequency, 16 different risetimes and ensure a short circuit shutdown. Safety control must be taken by the customer.

Figure 5: Available options for the HV dv/dt Pulse generator

Further, we offer testing services according to your specifications in-house in our laboratory.

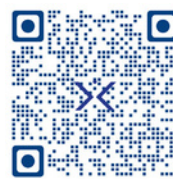

Meet us at PCIM 2024 - Hall 7 Stand 135. As every year, we will be exhibiting at PCIM 2024 in June. Perform your own live insulation tests and observe the generator in operation during a cup of coffee. Alternatively, we would be happy to talk to you sooner.

[www.saxogy.de](http://www.saxogy.de)



**Konrad Domes:** "SAXOGY® has been developing safety test benches and test generators for power electronic systems and components for 20 years."

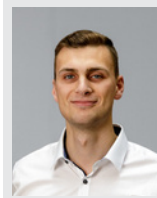

**Philipp Berkemeier:** "Progress in developing fast-switching devices is necessary and desirable - but it also presents new challenges in terms of stressing insulation systems. These challenges should be considered in the development of power electronic systems."



**Benjamin Sahan:** "Our jointly developed modular dv/dt pulse generator sets new standards in motor insulation testing. The innovative and highly reliable concept is the perfect solution for demanding testing applications."